

PRESTIGE INDUSTRIAL PIPEWORK EQUIPMENT LTD.

Unit L10, Telford Road, Bicester, Oxon, OX26 4LD

Tel: +44 (0) 1869 324424 Fax: +44 (0) 1869 323273

Web: www.pipe-ltd.com Email: sales@pipe-ltd.com

HYPERCUTTER



PRESTIGE INDUSTRIAL PIPEWORK EQUIPMENT LTD.

Unit L10, Telford Road, Bicester, Oxon, OX26 4LD

Tel: +44 (0) 1869 324424 Fax: +44 (0) 1869 323273

Web: www.pipe-ltd.com Email: sales@pipe-ltd.com



PRESTIGE INDUSTRIAL PIPEWORK EQUIPMENT

HYPERCUTTER Range O/D 1625-2438 mm (60"-96")

- Pipe cold cutting and bevelling machines



Pipe Ltd introduce the HYPERCUTTER. A hydraulic cold cutting and bevelling machine for the heaviest of applications, suitable for factory or on-site work.

RANGE:
60" - 96" b/b.

FUNCTIONS:
PIPE COLD CUTTING , BEVELLING ,
FACING , COUNTERBORING.

MATERIALS:
CARBON STEEL , ALLOY , STAINLESS
STEEL , DUPLEX..

POWER:
HYDRAULIC

NOTE:
THE HYPERCUTTER RANGE
OF PORTABLE PIPE CUTTING &
BEVELLING MACHINES ARE DESIGNED
TO MEET ON SITE HEAVY DUTY
REQUIREMENTS ON LARGE PIPELINE
DIAMETERS.
SPLIT FRAME BODY AND COPIER
TOOLBOXES ARE STANDARD
FEATURES.



Extremely rugged in design, the Hypercutter is equipped with 8 heavy duty locking feet for rapid set up on all pipe diameters within its range.



The unit is also equipped with two copier toolboxes with the spring loaded pipe OD tracking system, minimizing the bevel offset on out of round pipe.



As with all Pipe Ltd's Cold Cutting & Beveling machines, the Hypercutter is a split frame design for ease of set up and operation along pipelines.

TECHNICAL FEATURES

Nominal hydraulic motor power	hp(kw)	40,2(30)
Hydraulic motor working power	hp(kw)	33,5(25)
Oil flow rate	gpm	15,84
Oil pressure	psi	1740
Oil hose connection	inches	3/4
Radial feed rate per revolution	inches	0,008
Tool box stroke	inches	2,75
Max noise level	dB	75

O/D RANGE	SUPPLY	gg/min rpm	WEIGHT	A	B	C
60" - 72"	Hydraulic	7	1550	2830	2465	513
72" - 84"	Hydraulic	7	1750	3000	2771	513
84" - 96"	Hydraulic	7	1930	3300	3075	513

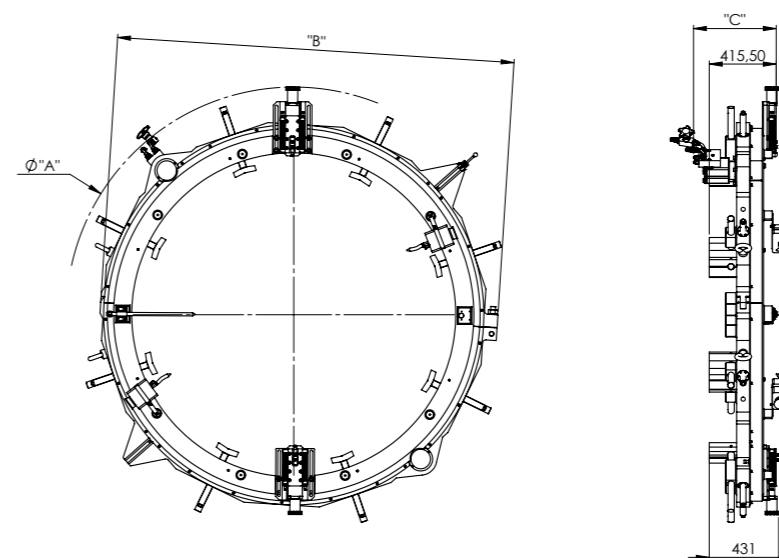

MODELS FROM 60" UP TO 96"

OPTIONALS



COLLECTING TRAY
TANK FOR COLLECTING SWARF ON
DUTY, EQUIPPED WITH FORCED
COOLANT CIRCULATION.



HYDRAULIC POWER PACK OIL TANK 250 L,
WITH REMOTE CONTROL AND INTER -
COOLER FOR EXTREMELY HEAVY DUTY
WORKING SESSION & ENVIRONMENTAL.

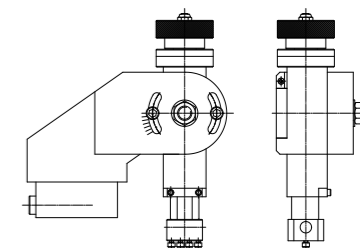

**TOOLBOX FOR INSIDE BEVEL AND ID
BORING UP TO 100 MM DEPTH**

